

E-Z Burr Tool Specifications – HSS Series

E-Z Burr Series L1A-L1B

For holes .093" through .153" (2.38mm to 3.90mm).

Tool #	Hole diameter (F)		Shank diameter (E)		Blade Series	
	Inches	mm	Inches	mm		
EZL 0093	3/32	0.0937	2.38	.236	6.00	L1A
EZL 0098		0.0984	2.50	.236	6.00	L1A
EZL 0102		0.1023	2.60	.236	6.00	L1A
EZL 0106		0.1062	2.70	.236	6.00	L1A
EZL 0109	7/64	0.1093	2.77	.236	6.00	L1A
EZL 0114		0.1141	2.90	.236	6.00	L1A
EZL 0118		0.1181	3.00	.236	6.00	L1A
EZL 0122		0.1220	3.10	.236	6.00	L1B
EZL 0125	1/8	0.1250	3.17	.236	6.00	L1B
EZL 0129		0.1299	3.30	.236	6.00	L1B
EZL 0133		0.1338	3.40	.236	6.00	L1B
EZL 0137		0.1378	3.50	.236	6.00	L1B
EZL 0140	9/64	0.1406	3.57	.236	6.00	L1B
EZL 0145		0.1456	3.70	.236	6.00	L1B
EZL 0149		0.1496	3.80	.236	6.00	L1B
EZL 0153		0.1535	3.90	.236	6.00	L1B

Note: Series L1A and L1B tools have a working range of -0.0+.006 inches and -.03+.15mm.

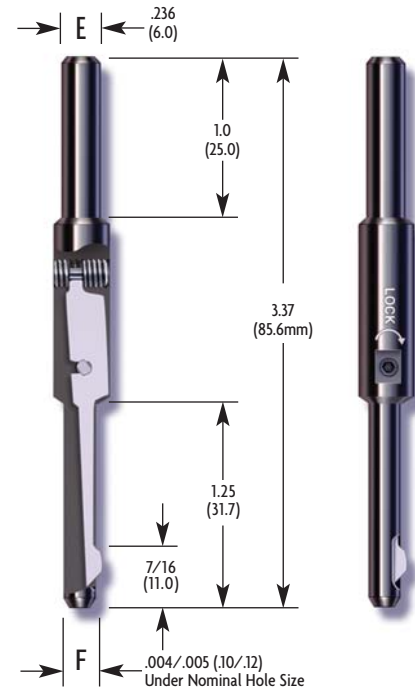

E-Z Burr Series L2A-L2B

For holes .156" through .236" (3.96mm to 6.0mm).

Tool #	Hole diameter (F)		Shank diameter (E)		Blade Series	
	Inches	mm	Inches	mm		
EZL 0156	5/32	0.1562	3.96	.250	6.35	L2A
EZL 0157		0.1574	4.00	.236	6.00	L2A
EZL 0165		0.1653	4.20	.236	6.00	L2A
EZL 0171	11/64	0.1718	4.36	.250	6.35	L2A
EZL 0177		0.1771	4.50	.236	6.00	L2A
EZL 0187	3/16	0.1875	4.76	.250	6.35	L2B
EZL 0196		0.1968	5.00	.236	6.00	L2B
EZL 0203	13/64	0.2031	5.15	.250	6.35	L2B
EZL 0208		0.2086	5.30	.236	6.00	L2B
EZL 0216		0.2165	5.50	.236	6.00	L2B
EZL 0218	7/32	0.2185	5.55	.250	6.35	L2B
EZL 0228		0.2283	5.80	.236	6.00	L2B
EZL 0234	15/64	0.2343	5.95	.250	6.35	L2B
EZL 0236		0.2362	6.00	.236	6.00	L2B

Note: Series L2A and L2B tools have a working range of -0.0+.016 inches and -.10+.40mm.

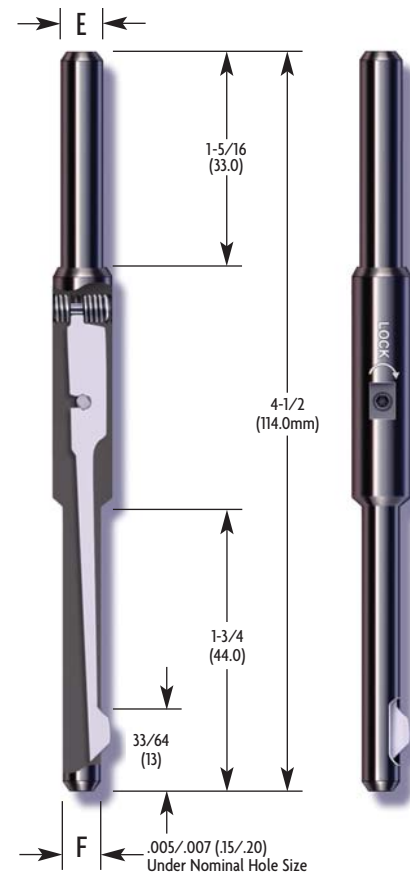

E-Z Burr Series L3A

For holes .250" through .334" (6.35mm to 8.50mm).

Tool #	Hole diameter (F)		Shank diameter (E)		Blade Series	
	Inches	mm	Inches	mm		
EZL 0250	1/4	0.2500	6.35	.359	9.10	L3A
EZL 0255		0.2559	6.50	.354	9.00	L3A
EZL 0265	17/64	0.2656	6.74	.359	9.10	L3A
EZL 0275		0.2755	7.00	.354	9.00	L3A
EZL 0281	9/32	0.2812	7.14	.359	9.10	L3A
EZL 0287		0.2874	7.30	.354	9.00	L3A
EZL 0295		0.2953	7.50	.354	9.00	L3A
EZL 0296	19/64	0.2968	7.54	.359	9.10	L3A
EZL 0305		0.3051	7.75	.354	9.00	L3A
EZL 0312	5/16	0.3125	7.93	.359	9.10	L3A
EZL 0314		0.3149	8.00	.354	9.00	L3A
EZL 0328	21/64	0.3281	8.33	.359	9.10	L3A
EZL 0334		0.3346	8.50	.354	9.00	L3A

Note: Series L3A and L3B tools have a working range of $-0.004+0.015$ inches and $-.10+.40$ mm.

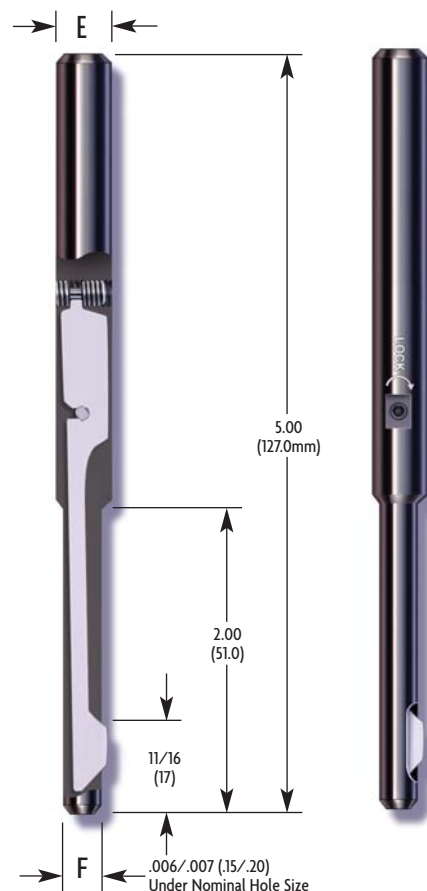

E-Z Burr Series L3B

For holes .343" through .500" (8.73mm to 12.70mm).

Tool #	Hole diameter (F)		Blade Series	
	Inches	mm		
EZL 0343	11/32	0.3437	8.73	L3B
EZL 0354		0.3543	9.00	L3B
EZL 0359	23/64	0.3593	9.12	L3B
EZL 0366		0.3661	9.30	L3B
EZL 0374		0.3740	9.50	L3B
EZL 0375	3/8	0.3750	9.52	L3B
EZL 0381		0.3818	9.70	L3B
EZL 0390	25/64	0.3906	9.92	L3B
EZL 0393		0.3937	10.00	L3B
EZL 0406	13/32	0.4062	10.31	L3B
EZL 0413		0.4133	10.50	L3B
EZL 0421	27/64	0.4218	10.71	L3B
EZL 0433		0.4330	11.00	L3B
EZL 0437	7/16	0.4375	11.11	L3B
EZL 0444		0.4448	11.30	L3B
EZL 0453	29/64	0.4531	11.50	L3B
EZL 0460		0.4606	11.70	L3B
EZL 0468	15/32	0.4687	11.90	L3B
EZL 0472		0.4724	12.00	L3B
EZL 0484	31/64	0.4843	12.30	L3B
EZL 0492		0.4921	12.50	L3B
EZL 0500	1/2	0.5000	12.70	L3B

Note: Series L3A and L3B tools have a working range of $-0.004+.04$ inches and $-.10+.10$ mm.

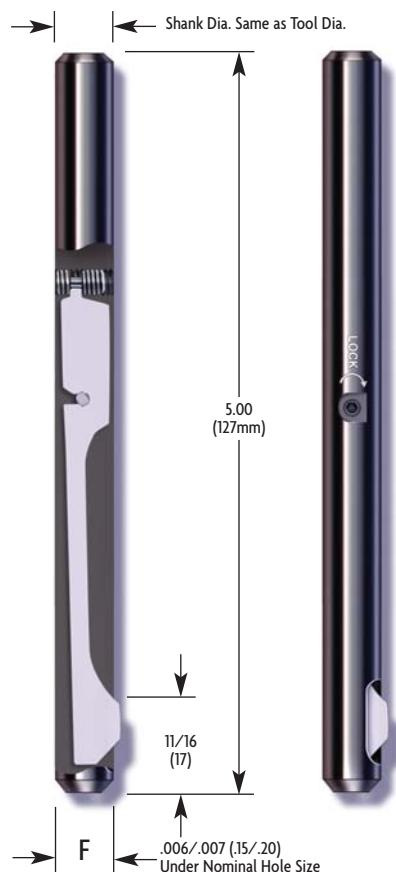

E-Z Burr Tool Specifications – HSS Series

E-Z Burr Series L3B

For holes .511" through .671" (13.00mm to 17.06mm).

Tool #	Hole diameter (F)		Shank diameter (E)		Blade Series	
	Inches	mm	Inches	mm		
EZL 0511		0.5118	13.00	.472	12.0	L3B
EZL 0515	33/64	0.5156	13.09	.500	12.7	L3B
EZL 0531	17/32	0.5312	13.49	.500	12.7	L3B
EZL 0546	35/64	0.5468	13.89	.500	12.7	L3B
EZL 0551		0.5511	14.00	.472	12.0	L3B
EZL 0562	9/16	0.5625	14.28	.500	12.7	L3B
EZL 0570		0.5708	14.50	.472	12.0	L3B
EZL 0578	37/64	0.5781	14.68	.500	12.7	L3B
EZL 0590		0.5905	15.00	.472	12.0	L3B
EZL 0593	19/32	0.5937	15.08	.500	12.7	L3B
EZL 0600		0.6003	15.25	.472	12.0	L3B
EZL 0610	39/64	0.6093	15.47	.500	12.7	L3B
EZL 0625	5/8	0.6250	15.87	.500	12.7	L3B
EZL 0629		0.6299	16.00	.472	12.0	L3B
EZL 0640	41/64	0.6406	16.27	.500	12.7	L3B
EZL 0649		0.6496	16.50	.472	12.0	L3B
EZL 0656	21/32	0.6562	16.66	.500	12.7	L3B
EZL 0669		0.6692	17.00	.472	12.0	L3B
EZL 0671	43/64	0.6718	17.06	.500	12.7	L3B

For holes .687" through 1.00" (17.46mm to 24.00mm).

Tool #	Hole diameter (F)		Shank diameter (E)		Blade Series	
	Inches	mm	Inches	mm		
EZL 0687	11/16	0.6875	17.46	.500	12.7	L3B
EZL 0703	45/64	0.7031	17.85	.500	12.7	L3B
EZL 0708		0.7086	18.00	.472	12.0	L3B
EZL 0718	23/32	0.7187	18.25	.500	12.7	L3B
EZL 0734	47/64	0.7343	18.65	.500	12.7	L3B
EZL 0748		0.7480	19.00	.472	12.0	L3B
EZL 0750	3/4	0.7500	19.05	.500	12.7	L3B
EZL 0763	49/64	0.7656	19.44	.500	12.7	L3B
EZL 0781	25/32	0.7812	19.84	.500	12.7	L3B
EZL 0787		0.7874	20.00	.472	12.0	L3B
EZL 0796	51/64	0.7968	20.24	.500	12.7	L3B
EZL 0812	13/16	0.8125	20.63	.500	12.7	L3B
EZL 0826		0.8267	21.00	.472	12.0	L3B
EZL 0843	27/32	0.8437	21.43	.500	12.7	L3B
EZL 0859	55/64	0.8593	21.82	.500	12.7	L3B
EZL 0866		0.8661	22.00	.472	12.0	L3B
EZL 0875	7/8	0.8750	22.22	.500	12.7	L3B
EZL 0890	57/64	0.8906	22.62	.500	12.7	L3B
EZL 0905		0.9055	23.00	.472	12.0	L3B
EZL 0906	29/32	0.9062	23.01	.500	12.7	L3B
EZL 0921	59/64	0.9218	23.41	.500	12.7	L3B
EZL 0937	15/16	0.9375	23.81	.500	12.7	L3B
EZL 0944		0.9448	24.00	.472	12.0	L3B
EZL 0953	61/64	0.9531	24.20	.500	12.7	L3B
EZL 0968	31/32	0.9687	24.60	.500	12.7	L3B
EZL 0984		0.9842	25.00	.472	12.0	L3B
EZL 1000	1.0	1.0000	25.40	.500	12.7	L3B

Note: Series L3B tools for these hole ranges have a working range of -0.004+.04 inches and -.10+1.0mm.

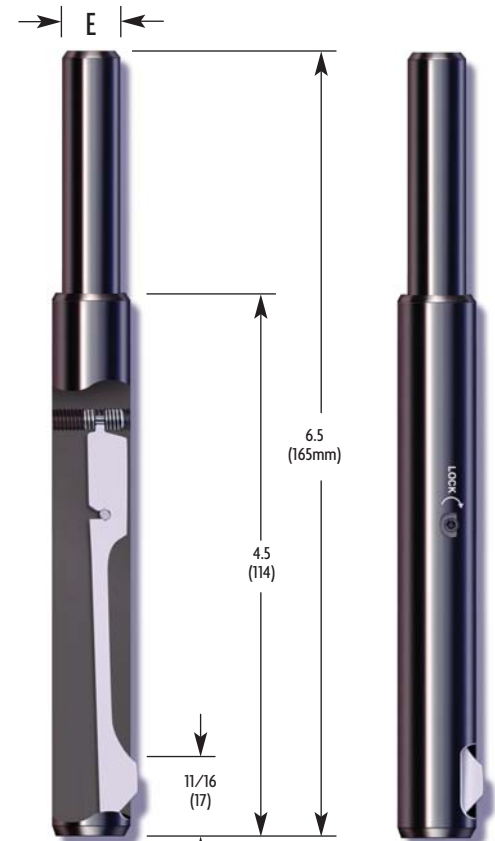

F ← .007/.010 (.17/.25) Under Nominal Hole Size

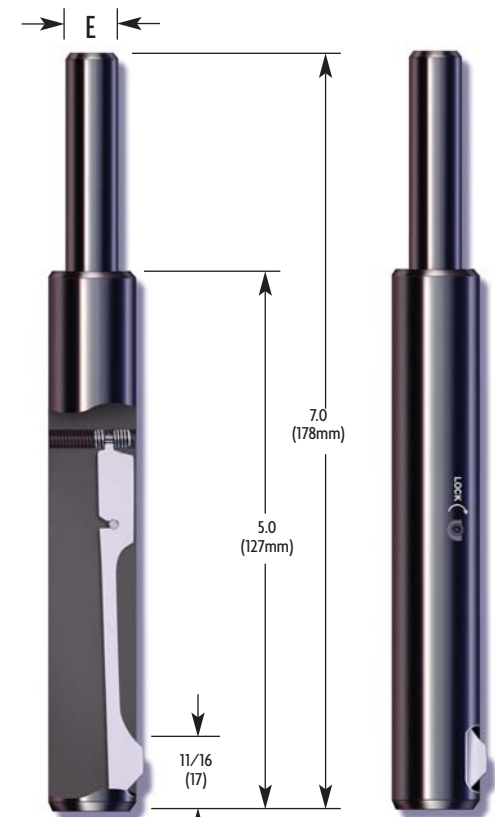

F ← .007/.010 (.17/.25) Under Nominal Hole Size

E-Z Burr Series L3B

For holes 1.023" through 2.0" (26.00mm to 50.80mm).

Tool #	Hole diameter (F)		Shank diameter (E)		Blade Series	
	Inches	mm	Inches	mm		
EZL 1023		1.0236	26.00	.472	12.0	L3B
EZL 1062	1 1/16	1.0625	26.98	.500	12.7	L3B
EZL 1063		1.0629	27.00	.472	12.0	L3B
EZL 1102		1.1023	28.00	.472	12.0	L3B
EZL 1125	1 1/8	1.1250	28.57	.500	12.7	L3B
EZL 1141		1.1417	29.00	.472	12.0	L3B
EZL 1181		1.1811	30.00	.472	12.0	L3B
EZL 1187	1 3/16	1.1875	30.16	.500	12.7	L3B
EZL 1220		1.2204	31.00	.472	12.0	L3B
EZL 1250	1 1/4	1.2500	31.75	.500	12.7	L3B
EZL 1259		1.2598	32.00	.472	12.0	L3B
EZL 1299		1.2992	33.00	.472	12.0	L3B
EZL 1312	1 5/16	1.3125	33.33	.500	12.7	L3B
EZL 1338		1.3385	34.00	.472	12.0	L3B
EZL 1375	1 3/8	1.3750	34.92	1.000	25.4	L3B
EZL 1377		1.3779	35.00	.984	25.0	L3B
EZL 1417		1.4173	36.00	.984	25.0	L3B
EZL 1437	1 7/16	1.4375	36.51	1.000	25.4	L3B
EZL 1456		1.4566	37.00	.984	25.0	L3B
EZL 1496		1.4960	38.00	.984	25.0	L3B
EZL 1500	1 1/2	1.5000	38.10	1.000	25.4	L3B
EZL 1535		1.5354	39.00	.984	25.0	L3B
EZL 1562	1 9/16	1.5625	39.68	1.000	25.4	L3B
EZL 1574		1.5748	40.00	.984	25.0	L3B
EZL 1614		1.6141	41.00	.984	25.0	L3B
EZL 1625	1 5/8	1.6250	41.27	1.000	25.4	L3B
EZL 1653		1.6535	42.00	.984	25.0	L3B
EZL 1692		1.6929	43.00	.984	25.0	L3B
EZL 1732		1.7322	44.00	.984	25.0	L3B
EZL 1750	1 3/4	1.7500	44.45	1.000	25.4	L3B
EZL 1771		1.7716	45.00	.984	25.0	L3B
EZL 1811		1.8110	46.00	.984	25.0	L3B
EZL 1850		1.8503	47.00	.984	25.0	L3B
EZL 1875	1 7/8	1.8750	47.62	1.000	25.4	L3B
EZL 1889		1.8897	48.00	.984	25.0	L3B
EZL 1929		1.9291	49.00	.984	25.0	L3B
EZL 1968		1.9685	50.00	.984	25.0	L3B
EZL 2000	2.00	2.0000	50.80	1.000	25.4	L3B

*Larger tools available upon request.

Note: Series L3B tools for these hole ranges have a working range of -.004+.04 inches and -.10+.10mm.

